



STEEL SCAFFOLD HOOK

Ref. 71160

TECHNICAL SHEET

CE 0120

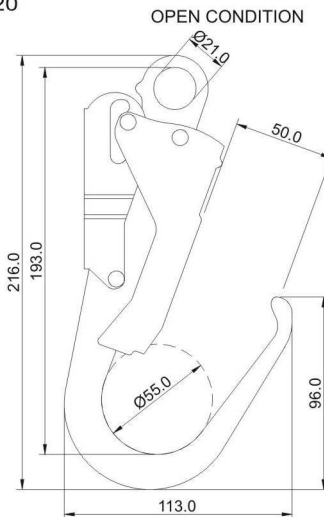
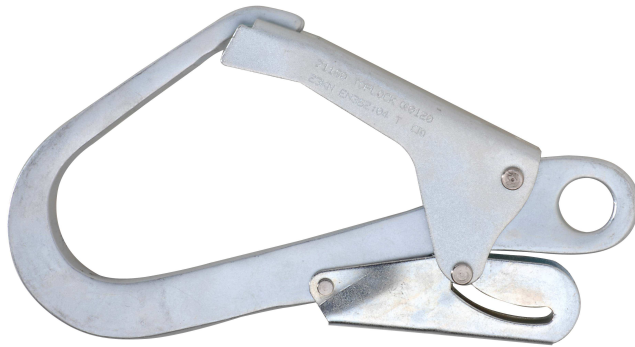

CLOSED CONDITION

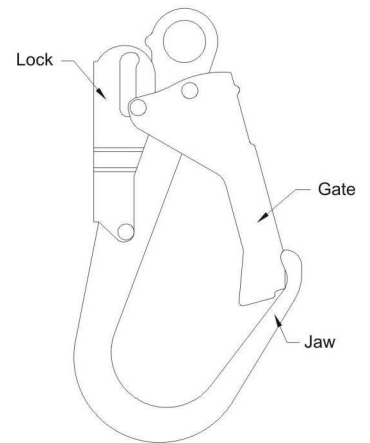

Tested as per EN 362 -1993

Gencode :
3435241 711601

GENERAL DESCRIPTION AND MATERIALS

- Material : **steel**
- Double secured closing system
- Finishing : nickel chrome plated for better finish and corrosion protection
- Strength: > **23KN**
- Size : **216.0 x 113.0 mm**
- **Max. opening : 50.0 mm**
- Diameter for access of the rope or connector : 21 mm
- Weight : 480 g (+/- 10%)

SPECIFIC ADVANTAGES

- **Strength**
- **Secured opening and closing system**

MAIN APPLICATION FIELDS

- Job in **high places** in combination with a **fall arrestor system** or a **work positioning system**.
- Construction engineering
- Mountainous environment

PACKAGING

- **Individual packing**
- **Carton of 25 hooks**

STANDARDIZATION

This hook is in conformity with the model of individual safety equipment which correspond to **EN 362:2004** The **CE Type-examination certificate 2344 Issue 2 Extension 6**

Delivered by **SATRA (notified body n° 0321)**



EUROPROTECTION - 420, rue de la Dombes - 01700 MIRIBEL - FRANCE