

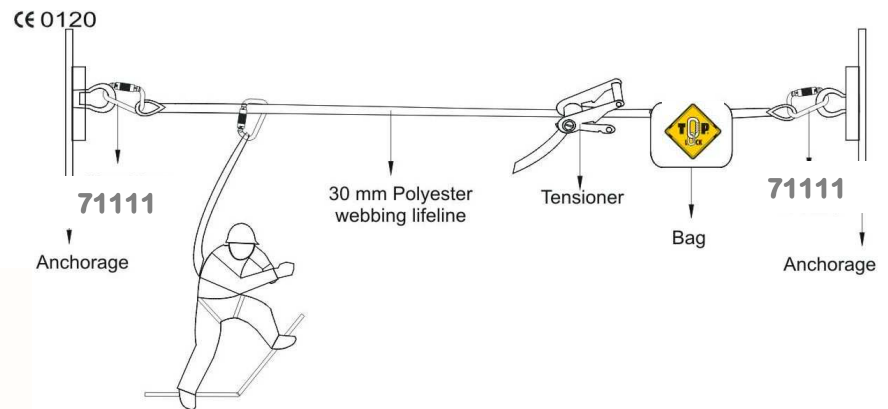

# TEMPORARY HORIZONTAL ANCHORAGE LINE

Ref. 71750

TECHNICAL SHEET



tested as per EN 795, 1996

Gencode :

3435241 717504

## GENERAL DESCRIPTION AND MATERIALS

- Red polyamide weaved lanyard
- Width : 30 mm
- Length : from 3.0m to 20.0m
- Static strength: > 11KN
- Equipped with ratchet tensioner
- Weight : 3450 g (+/-10%)
- Breaking strength minimum : 25KN

## SPECIFIC ADVANTAGES

- 2 reinforced stitched loops
- Delivered with 2 connectors 71111

## MAIN APPLICATION FIELDS

- Job in **high places** in combination with a **fall arrestor system** or a **work positioning system**.
- **Construction and civil engineering**
- Can be used by 2 peoples at the same time
- Dynamic strength: **mass of 100Kg maximum**
- **To be used horizontally only**
- **Attachment** between this lanyard and any other equipment or anchorage point shall only be carried out with connectors in accordance with EN 362.

## PACKAGING

- Individual packing in a black bag
- Carton of 5 anchorage lines

## NORMALISATION

This anchorage line is in conformity with the model of individual safety equipment which correspond to

EN 795:1996

The CE Type-examination certificate 3559 Issue 1 Extension 3



Delivered by SATRA (notified body n° 0321)

EUROPROTECTION - 420, rue de la Dombes - 01700 MIRIBEL - FRANCE